

Kegelradgetriebe Bevel Gear Units

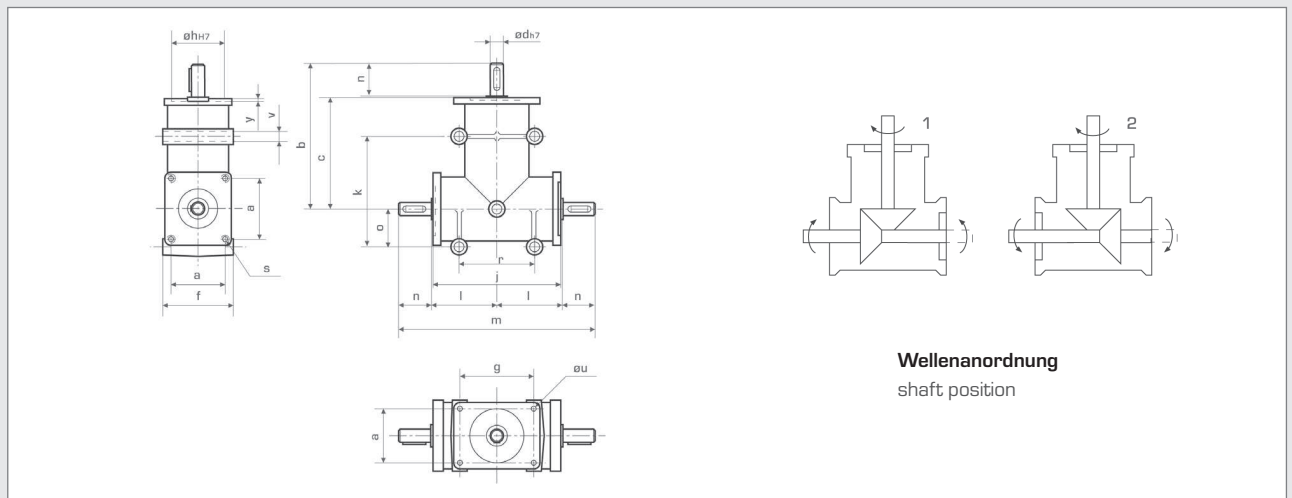

1 Antriebswelle, 2 Abtriebswellen | 1 input shaft, 2 output shafts

$n_1=1400 \text{ min}^{-1}$																					Bestell Nr.	
i	P_{an}	M_{t2}	a	b	c	d	f	g	h	j	k	l	m	n	o	r	s	u	v	y	[kg]	Part No.
	[kW]	[Nm]																				
1:1	0,42	3,0	30	81	60	8*)	43	40	30	75	55	38,5	117	20	20	40	M 4	5	5	2,5	0,5	558-002-201
2:1	0,10	1,5	30	81	60	8*)	43	40	30	75	55	38,5	117	20	20	40	M 4	5	5	2,5	0,5	558-002-202

1 Antriebswelle, 1 Abtriebswelle/ Wellenanordnung 1 | 1 input shaft, 1 output shaft/ shaft position 1

$n_1=1400 \text{ min}^{-1}$																					Bestell Nr.	
i	P_{an}	M_{t2}	a	b	c	d	f	g	h	j	k	l	n	o	r	s	u	v	y	[kg]	Part No.	
	[kW]	[Nm]																				
1:1	0,42	3,0	30	81	60	8*)	43	40	30	75	55	38,5		20	20	40	M 4	5	5	2,5	0,5	558-000-001
2:1	0,10	1,5	30	81	60	8*)	43	40	30	75	55	38,5		20	20	40	M 4	5	5	2,5	0,5	558-000-002

1 Antriebswelle, 1 Abtriebswelle/ Wellenanordnung 2 | 1 input shaft, 1 output shaft/ shaft position 2

$n_1=1400 \text{ min}^{-1}$																					Bestell Nr.	
i	P_{an}	M_{t2}	a	b	c	d	f	g	h	j	k	l	n	o	r	s	u	v	y	[kg]	Part No.	
	[kW]	[Nm]																				
1:1	0,42	3,0	30	81	60	8*)	43	40	30	75	55	38,5		20	20	40	M 4	5	5	2,5	0,5	558-000-101
2:1	0,10	1,5	30	81	60	8*)	43	40	30	75	55	38,5		20	20	40	M 4	5	5	2,5	0,5	558-000-102

1 Antriebswelle, 2 Abtriebswellen | 1 input shaft, 2 output shafts

$n_1=1400 \text{ min}^{-1}$																					Bestell Nr.	
i	P_{an}	M_{t2}	a	b	c	d	f	g	h	j	k	l	m	n	o	r	s	u	v	y	[kg]	Part No.
	[kW]	[Nm]																				
1:1	1,83	13,0	46	121	90	14	70	46	47	110	95	56	172	30	32	60	M 8	M 8	8,5	3	2	558-008-201
2:1	0,50	7,0	46	121	90	14	70	46	47	110	95	56	172	30	32	60	M 8	M 8	8,5	3	2	558-008-202
3:1	0,25	5,0	46	121	90	14	70	46	47	110	95	56	172	30	32	60	M 8	M 8	8,5	3	2	558-008-203

Kegelradgetriebe Bevel Gear Units

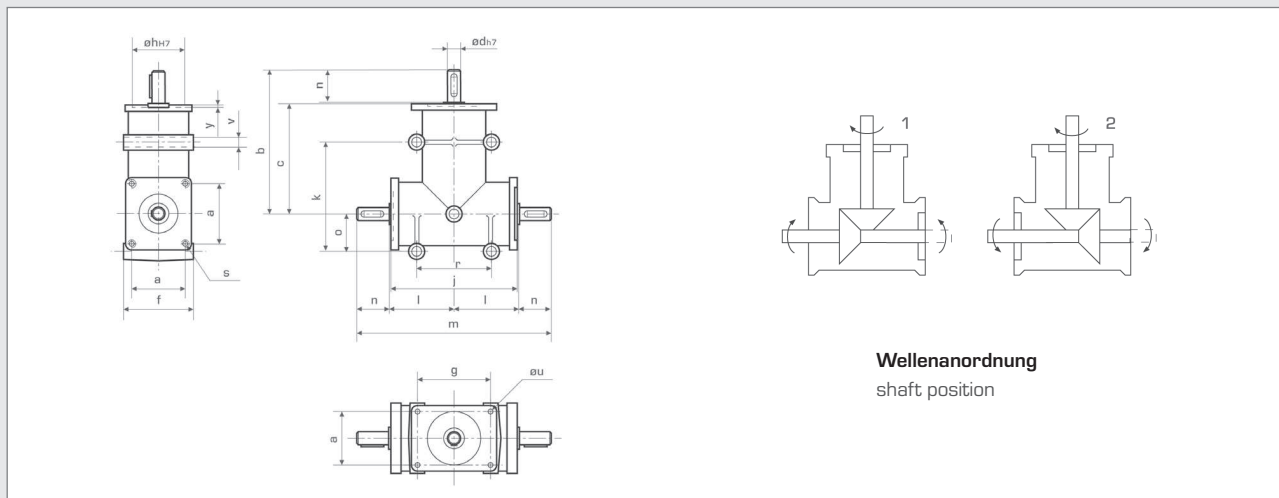

1 Antriebswelle, 1 Abtriebswelle/ Wellenanordnung 1 | 1 input shaft, 1 output shaft/ shaft position 1

$n_1 = 1400 \text{ min}^{-1}$

i	P_{an} [kW]	M_{t2} [Nm]	a	b	c	d	f	g	h	j	k	l	n	o	r	s	u	v	y	[kg]	Bestell Nr.
																					Part No.
1:1	1,83	13,0	46	121	90	14	70	46	47	110	95	56	30	32	60	M 8	M 8	8,5	3	2	558-011-001
2:1	0,50	7,0	46	121	90	14	70	46	47	110	95	56	30	32	60	M 8	M 8	8,5	3	2	558-011-002
3:1	0,25	5,0	46	121	90	14	70	46	47	110	95	56	30	32	60	M 8	M 8	8,5	3	2	558-011-003

1 Antriebswelle, 1 Abtriebswelle/ Wellenanordnung 2 | 1 input shaft, 1 output shaft/ shaft position 2

$n_1 = 1400 \text{ min}^{-1}$

i	P_{an} [kW]	M_{t2} [Nm]	a	b	c	d	f	g	h	j	k	l	n	o	r	s	u	v	y	[kg]	Bestell Nr.
																					Part No.
1:1	1,83	13,0	46	121	90	14	70	46	47	110	95	56	30	32	60	M 8	M 8	8,5	3	2	558-011-101
2:1	0,50	7,0	46	121	90	14	70	46	47	110	95	56	30	32	60	M 8	M 8	8,5	3	2	558-011-102
3:1	0,25	5,0	46	121	90	14	70	46	47	110	95	56	30	32	60	M 8	M 8	8,5	3	2	558-011-103

Bei Übersetzungen ins Schnelle $n_{2max} = 1400 \text{ min}^{-1}$

Kegelräder: Einsatzstahl, spiralverzahnt, einsatzgehärtet und geläppt.

Gehäuse: Leichtmetall-Legierung

Öl: 10 - 12° E bei 50 °C

Keilnuten nach DIN 6885/1

*) ohne Nut

at ratios to speed $n_{2max} = 1400 \text{ r.p.m.}$

bevel gears: spiral teeth, case hardened steel, lapped.

case: light metal alloy

oil: 10 - 12° E at 50 °C

keyways acc. to DIN 6885/1

*) without keyway

Max. übertragbares Drehmoment je Getriebe | max. transmitting torque per unit
Antriebsleistung | input power

M_{t2} [Nm]
 P_{an} [kW]



Kegelradgetriebe

Bevel Gear Units

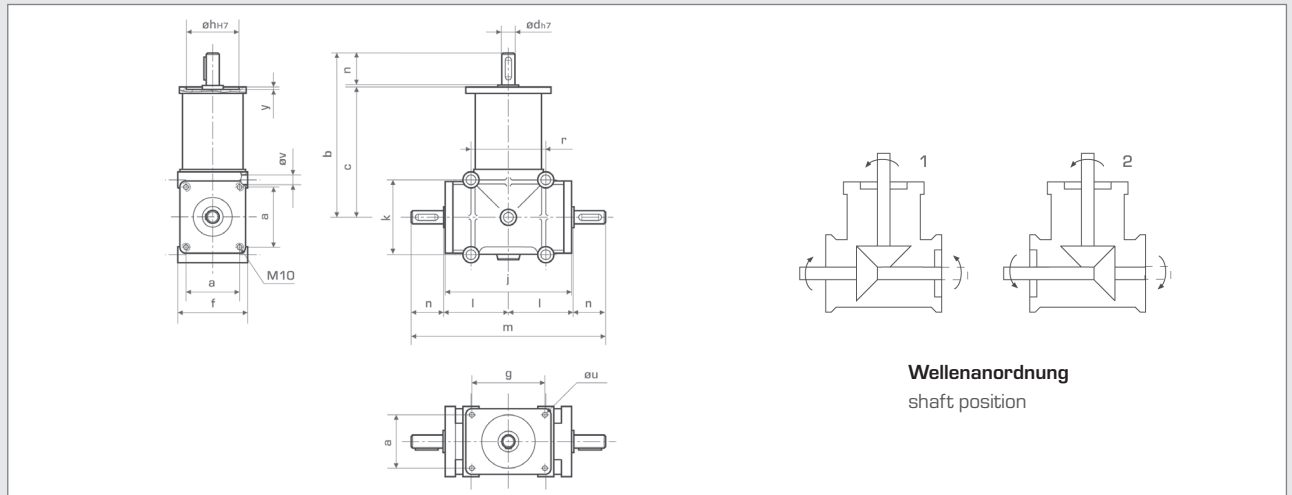

Wellenanordnung
shaft position

1 Antriebswelle, 2 Abtriebswellen | 1 input shaft, 2 output shafts

$n_1=1400 \text{ min}^{-1}$																				Bestell Nr.
i	P_{an}	M_{t2}	a	b	c	d	f	g	h	j	k	l	m	n	r	u	v	y	[kg]	Part No.
	[kW]	[Nm]																		
1:1	5,50	38,0	60	181	140	19	86	80	62	150	86	76	232	40	86	10,5	10,5	5	4,4	558-031-201
2:1	1,83	25,0	60	181	140	19	86	80	62	150	86	76	232	40	86	10,5	10,5	5	4,4	558-031-202
3:1	0,91	18,0	60	181	140	19	86	80	62	150	86	76	232	40	86	10,5	10,5	5	4,4	558-031-203

1 Antriebswelle, 1 Abtriebswelle/ Wellenanordnung 1 | 1 input shaft, 1 output shaft/ shaft position 1

$n_1=1400 \text{ min}^{-1}$																				Bestell Nr.
i	P_{an}	M_{t2}	a	b	c	d	f	g	h	j	k	l	n	r	u	v	y	[kg]	Part No.	
	[kW]	[Nm]																		
1:1	5,50	38,0	60	181	140	19	86	80	62	150	86	76		40	86	10,5	10,5	5	4,4	558-030-001
2:1	1,83	25,0	60	181	140	19	86	80	62	150	86	76		40	86	10,5	10,5	5	4,4	558-030-002
3:1	0,91	18,0	60	181	140	19	86	80	62	150	86	76		40	86	10,5	10,5	5	4,4	558-030-003

1 Antriebswelle, 1 Abtriebswelle/ Wellenanordnung 2 | 1 input shaft, 1 output shaft/ shaft position 2

$n_1=1400 \text{ min}^{-1}$																				Bestell Nr.
i	P_{an}	M_{t2}	a	b	c	d	f	g	h	j	k	l	n	r	u	v	y	[kg]	Part No.	
	[kW]	[Nm]																		
1:1	5,50	38,0	60	181	140	19	86	80	62	150	86	76		40	86	10,5	10,5	5	4,4	558-030-101
2:1	1,83	25,0	60	181	140	19	86	80	62	150	86	76		40	86	10,5	10,5	5	4,4	558-030-102
3:1	0,91	18,0	60	181	140	19	86	80	62	150	86	76		40	86	10,5	10,5	5	4,4	558-030-103

1 Antriebswelle, 1 Abtriebshohlwelle | 1 input shaft, 1 output hollow shaft

$n_1=1400 \text{ min}^{-1}$																				Bestell Nr.
i	P_{an}	M_{t2}	a	b	c	d	f	g	h	j	k	l	m	r	u	v	y	[kg]	Part No.	
	[kW]	[Nm]																		
1:1	5,50	38,0	60	181	140	19	86	80	62	150	86	76	152		86	10,5	10,5	5	4,8	558-228-201
2:1	1,83	25,0	60	181	140	19	86	80	62	150	86	76	152		86	10,5	10,5	5	4,8	558-228-202
3:1	0,91	18,0	60	181	140	19	86	80	62	150	86	76	152		86	10,5	10,5	5	4,8	558-228-203

Kegelradgetriebe Bevel Gear Units

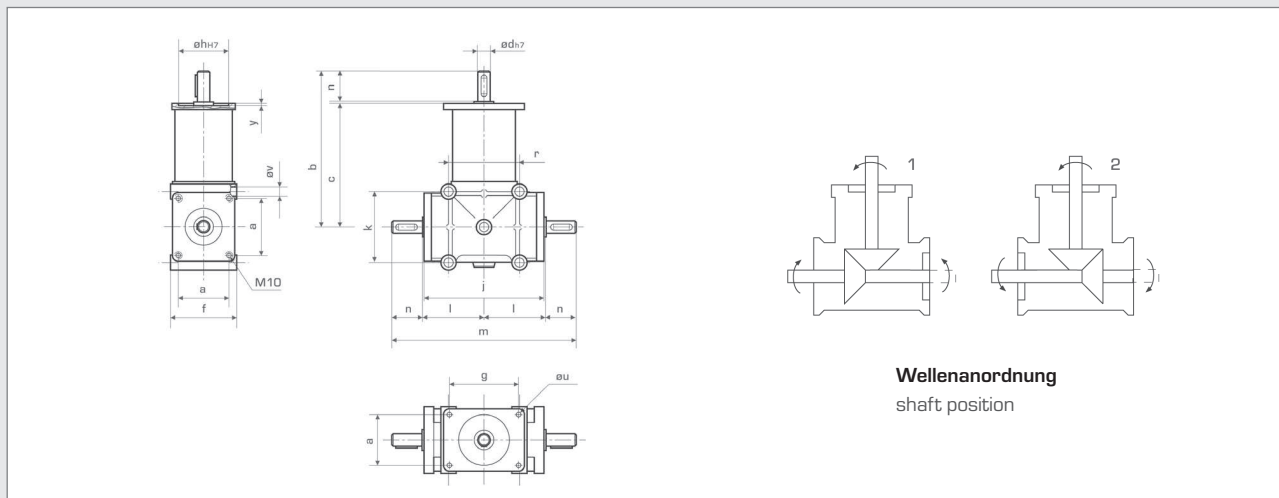

1 Antriebswelle, 2 Abtriebswellen | 1 input shaft, 2 output shafts

$n_1=1400 \text{ min}^{-1}$																				Bestell Nr.
i	P_{an}	M_{t2}	a	b	c	d	f	g	h	j	k	l	m	n	r	u	v	y	[kg]	Part No.
	[kW]	[Nm]																		
1:1	7,35	50,0	60	191	140	24	86	80	62	150	86	76	252	50	86	10,5	10,5	5	4,4	558-033-201
2:1	2,94	40,0	60	191	140	24	86	80	62	150	86	76	252	50	86	10,5	10,5	5	4,4	558-033-202
3:1	1,47	28,0	60	191	140	24	86	80	62	150	86	76	252	50	86	10,5	10,5	5	4,4	558-033-203

1 Antriebswelle, 1 Abtriebswelle/ Wellenanordnung 1 | 1 input shaft, 1 output shaft/ shaft position 1

$n_1=1400 \text{ min}^{-1}$																				Bestell Nr.
i	P_{an}	M_{t2}	a	b	c	d	f	g	h	j	k	l	n	r	u	v	y	[kg]	Part No.	
	[kW]	[Nm]																		
1:1	7,35	50,0	60	191	140	24	86	80	62	150	86	76		50	86	10,5	10,5	5	4,4	558-032-001
2:1	2,94	40,0	60	191	140	24	86	80	62	150	86	76		50	86	10,5	10,5	5	4,4	558-032-002
3:1	1,47	28,0	60	191	140	24	86	80	62	150	86	76		50	86	10,5	10,5	5	4,4	558-032-003

1 Antriebswelle, 1 Abtriebswelle/ Wellenanordnung 2 | 1 input shaft, 1 output shaft/ shaft position 2

$n_1=1400 \text{ min}^{-1}$																				Bestell Nr.
i	P_{an}	M_{t2}	a	b	c	d	f	g	h	j	k	l	n	r	u	v	y	[kg]	Part No.	
	[kW]	[Nm]																		
1:1	7,35	50,0	60	191	140	24	86	80	62	150	86	76		50	86	10,5	10,5	5	4,4	558-032-101
2:1	2,94	40,0	60	191	140	24	86	80	62	150	86	76		50	86	10,5	10,5	5	4,4	558-032-102
3:1	1,47	28,0	60	191	140	24	86	80	62	150	86	76		50	86	10,5	10,5	5	4,4	558-032-103

Bei Übersetzungen ins Schnelle $n_{2max} = 1400 \text{ min}^{-1}$

Kegelräder: Einsatzstahl, spiralverzahnt, einsatzgehärtet und geläppt.

Gehäuse: Leichtmetall-Legierung

Öl: 10 - 12° E bei 50 °C

Keilnuten nach DIN 6885/1

at ratios to speed $n_{2max} = 1400 \text{ r.p.m.}$

bevel gears: spiral teeth, case hardened steel, lapped.

case: light metal alloy

oil: 10 - 12° E at 50 °C

keyways acc. to DIN 6885/1

Max. übertragbares Drehmoment je Getriebe | max. transmitting torque per unit
Antriebsleistung | input power

M_{t2} [Nm]
 P_{an} [kW]



Kegelradgetriebe Bevel Gear Units

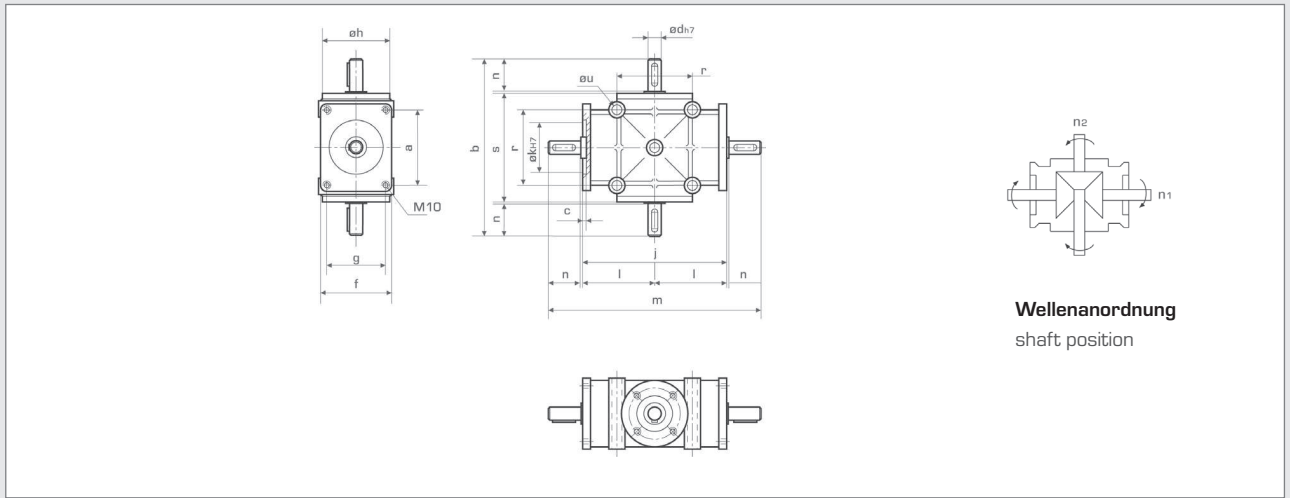

2 Antriebswellen, 2 Abtriebswellen | 2 input shafts, 2 output shafts

i	$n_1=1400 \text{ min}^{-1}$		a	b	c	d	f	g	h	j	k	l	m	n	r	u	v	[kg]	Bestell Nr.
	P_{an} [kW]	M_{t2} [Nm]																	Part No.
1:1	7,35	54,0	80	231	3	24	86	60	84	182	62	92	284	50	86	131	11	5,35	558-026-201
2:1	2,94	42,0	80	231	3	24	86	60	84	182	62	92	284	50	86	131	11	5,35	558-026-202
3:1	1,47	27,0	80	231	3	24	86	60	84	182	62	92	284	50	86	131	11	5,35	558-026-203

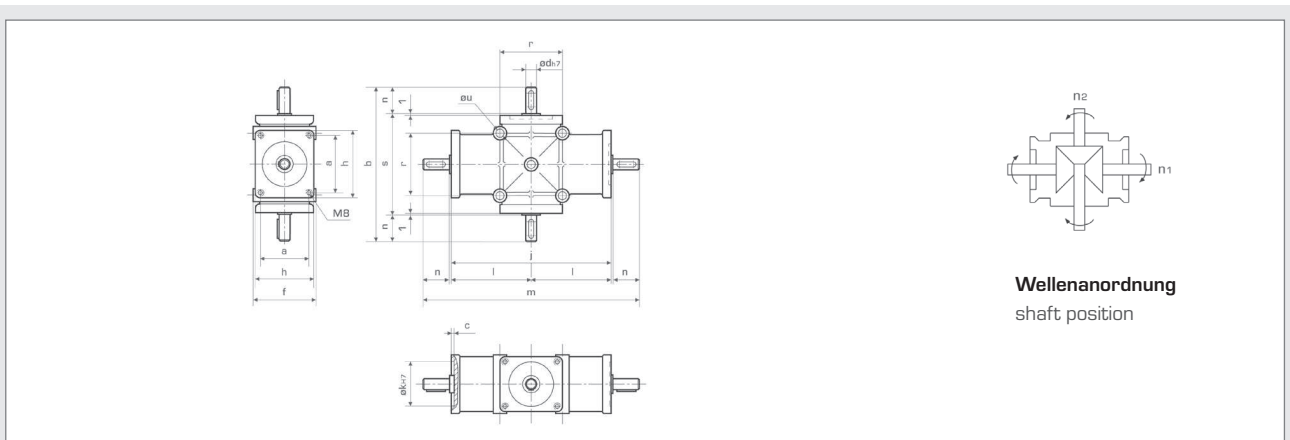

2 Antriebswellen, 2 Abtriebswellen | 2 input shafts, 2 output shafts

i	$n_1=1400 \text{ min}^{-1}$		a	b	c	d	f	h	j	k	l	m	n	r	u	v	[kg]	Bestell Nr.
	P_{an} [kW]	M_{t2} [Nm]																Part No.
1:1	1,83	13,5	46	172	3	14	70	64	180	47	91	242	30	62	112	8,5	3,25	558-006-201
2:1	0,50	7,5	46	172	3	14	70	64	180	47	91	242	30	62	112	8,5	3,25	558-006-202
3:1	0,25	5,1	46	172	3	14	70	64	180	47	91	242	30	62	112	8,5	3,25	558-006-203

Kegelräder: Einsatzstahl, spiralverzahnt, einsatzgehärtet und geläppt.
Gehäuse: Leichtmetall-Legierung
Öl: 10 - 12° E bei 50 °C
Keilnuten nach DIN 6885/1

bevel gears: spiral teeth, case hardened steel, lapped.
case: light metal alloy
oil: 10 - 12° E at 50 °C
keyways acc. to DIN 6885/1

Max. übertragbares Drehmoment je Getriebe | max. transmitting torque per unit
Antriebsleistung | input power

M_{t2} [Nm]
 P_{an} [kW]